



Invacare® Typhoon

*Electric wheelchair
Operating manual*

CE



How can you get in touch with Invacare®?

If you have any questions or need support, please contact your authorised Invacare® Dealer, who has the necessary know-how and equipment plus the special knowledge concerning your Invacare® product, and can offer you all-round satisfactory service. Should you wish to contact Invacare® directly, you can reach us in Europe at the following addresses and phone numbers.

Invacare® Deutschland GmbH

Kleiststraße 49
32457 Porta Westfalica

Deutschland

☎ (Kundendienst): +49 - (0) 5731 - 754 580
☎ (Technische Hotline): +49 - (0) 5731 - 754 570
Fax (Kundendienst): +49 - (0) 5731 - 754 216
Fax (Technische Hotline): +49 - (0) 5731 - 754 208

Invacare®, SA

c/ Areny, s/n
Poligon Industrial de Celrà
17460 Celrà (Girona)

ESPAÑA

☎ : +34 - (0) 972 - 49 32 00
Fax: +34 - (0) 972 - 49 32 20

Invacare® Ltd

South Road
Bridgend
Mid Glamorgan - CF31-3PY

United Kingdom

☎ (Customer Service): +44 - (0) 1656 - 647 327
Fax (Customer Service): +44 - (0) 1656 - 649 016

Invacare® A/S

Sdr. Ringvej 39
2605 Brøndby

Danmark

☎ (Kundeservice): +45 - (0) 3690 0000
Fax (Kundeservice): +45 - (0) 3690 0001

Invacare® POIRIER

Les Roches
F-37230 Fondettes

France

☎ (Service Après-Vente): +33 - (0) 2 47 - 62 64 66
Fax (Service Après-Vente): +33 - (0) 2 47 - 42 12 24

Invacare Mecc San s.r.l.

Via Dei Pini, 62
I - 36016 Thiene (VI)

ITALIA

☎: +39 - (0) 445-380059
Fax: +39 - (0) 445-380034

Invacare® AS

Grensesvingen 9
0603 Oslo

Norge

☎ (Kundeservice): +47 - 22 57 95 10
Fax (Kundeservice): +47 - 22 57 95 01

Invacare® PORTUGAL Lda

Rua Senhora de Campanhã, 105
4369-001 Porto

PORTUGAL

☎ : +351-225105946
Fax: +351-225105739

Invacare® n.v.

Autobaan 14
8210 Loppem (Brugge)

BELGIUM

☎: +32 (50) 831010
Fax: +32 (50) 831011

Invacare® B.V.

Celsiusstraat 46
NL-6716 BZ Ede

The Netherlands

☎ : +31 - (0) 318 - 69 57 57
Fax: +31 - (0) 318 - 69 57 58

Invacare® AB

Fagerstagatan 9
163 91 Spånga

Sverige

☎ (Kundtjänst): +46 - (0) 8 761 70 90
Fax (Kundtjänst): +46 - (0) 8 761 81 08
sweden@invacare.com

Service**Invacare****JÄRFÄLLA**

☎: +46 - (0) 8 – 621 08 44
Fax: +46 - (0) 8 – 621 08 45
invacare.jarfalla@swipnet.se

MÖLNDAL

☎: +46 - (0) 31 – 86 36 00
Fax: +46 - (0) 31 – 86 36 06
invacare.goteborg@swipnet.se

LANDSKRONA

☎: +46 - (0) 418 – 285 40
Fax: +46 - (0) 418 – 180 89
invacare.la@swipnet.se

OSKARSHAMN

☎: +46 - (0) 491 – 101 40
Fax: +46 - (0) 491 – 101 80
invacare.O-hamn@swipnet.se

Table of Contents

Chapter		Page
1	Introduction	8
1.1	Important symbols in this manual	10
1.2	Type Classification and Area of Use	11
1.2.1	Permissible operating conditions.....	11
1.2.2	Indications.....	12
2	Safety Notes	13
2.1	General Safety Notes	13
2.2	Safety Information on Electromagnetic Interference.....	16
2.3	Safety Information on Driving and Freewheel Mode.....	17
2.4	Safety Information on Wheelchairs with a Lifter	19
2.5	Safety Information on Wheelchairs with Recaro Seats	20
3	Key features	21
4	Getting in and out of the wheelchair	22
4.1	Remove the standard armrest in order to side transfer	22
4.2	Raise the parallel sliding armrest / remove the skirtguard (optional)	23
5	Driving	25
5.1	Before driving for the first time.....	25
5.2	Taking Obstacles.....	26
5.2.1	The "SureStep" System	26
5.2.2	The "Stability Lock" System.....	26
5.2.3	The components of the "SureStep" and the "Stability Lock" system.....	27

5.2.4	Maximum obstacle height	27
5.2.5	Safety information when ascending obstacles	28
5.2.6	Safety information when descending obstacles	28
5.2.7	The correct way to overcome obstacles	29
5.3	Driving up and down gradients.....	30
5.4	Parking and stationary.....	30
6	Pushing the wheelchair by hand	31
6.1	Manually disengaging conventional motors	31
6.2	Electrically disengaging GB motors.....	32
6.3	Manually disengaging GB motors (emergency disengaging)	33
7	The REM 24 SD Remote	34
7.1	Layout of the remote	34
7.2	ON/OFF diode (status display).....	37
7.3	Battery charger display.....	37
7.4	Activating / deactivating the immobilizer.....	38
7.5	Using the Buddy buttons with the remote	39
7.6	Controlling the wheelchair using the remote	40
7.6.1	How a wheelchair with "Indirect Steering" reacts to joystick movements.....	41
7.7	Operating the electric adjustment options	42
7.7.1	Activating adjustment mode.....	42
7.7.2	Selecting and operating the adjustment option	43
7.7.3	Changing back to driving mode	44
7.8	Error diagnosis	45
7.8.1	Error codes and diagnostic codes	46
8	Adjusting the wheelchair to the user's seating posture	48
8.1	Recaro® seats.....	48
8.2	Adjusting the armrests and the joystick box.....	49
8.2.1	Adapting the remote to the length of the user's arm	49

8.2.2	Setting the height of the remote	50
8.2.3	Setting the height of the armrests.....	51
8.2.4	Setting the width of the armrests	52
8.3	Manually adjusting the seat tilt	54
8.4	Manually adjusting the backrest.....	56
8.4.1	Adjusting the backrest using the gas pressure spring.....	56
8.4.1.1	Adjust the backrest using the perforated plate	57
8.4.2	Flex and Contour Seats.....	58
8.5	The Lifter	59
8.5.1	Explanation of symbols on lifter warning sticker.....	60
8.6	Legrests.....	61
8.6.1	Electric legrest	61
8.6.1.1	Completely lowering electrical legrests as dismounting aid	61
8.6.2	Adjustable legrest	62
8.6.2.1	Adjusting the angle	62
8.6.2.2	Adjusting the length of the legrest	63
8.6.2.3	Adjusting the calf plate to the calf width of the user	64
8.6.2.4	Adjusting the angle of the foot plate	65
9	Electrical System	66
9.1	Electronics Protection System	66
9.1.1	The main fuse	67
9.2	Batteries	68
9.2.1	What you need to know about batteries	68
9.2.2	Charging the batteries	70
9.2.3	Removing and fitting batteries	72
9.2.3.1	Removing the batteries.....	73
9.2.3.2	How to handle damaged batteries correctly	79
10	Care and maintenance	80
11	Repair Instructions	83

11.1	Repairing a flat tyre	83
11.1.1	Repairing punctures (drive wheel with conventional motor and pneumatic tyres)	84
11.1.2	Repairing punctures (drive wheel with GB motor and pneumatic tyres)	87
12	Refurbishment	90
13	Disposal	91
14	Technical Specifications	92
15	Inspections Performed	96

1 Introduction

Dear user,

First we would like to thank you for purchasing our product! We hope that you will have a great deal of pleasure with your new power chair

This operating manual contains important information and notes about:

- **Safety**
- **Operation**
- **Care and maintenance.**

Please take care to read the operating manual thoroughly before starting out on your first journey.

This wheelchair has been constructed for a large circle of users with different requirements.

The decision whether the model is suitable for the user may only be taken by medical specialists with appropriate expertise.

Invacare® or their statutory representatives can accept no liability in cases in which the wheelchair has not been adapted to suit the users' handicaps.

Some maintenance and settings can be carried out by the user or his attendants. Certain adjustments do however require technical training and may only be carried out by your Invacare® specialist dealer. Damages and errors caused by nonobservance of the operating manual or as a result of incorrect maintenance are excluded from all guarantees.

This manual contains copyrighted information. This manual may not be reproduced or reprinted either partly or completely without previous written consent from Invacare® or its statutory representatives. We reserve the right to make any necessary alterations on the grounds of technical improvements.

1.1 Important symbols in this manual



WARNING!

This symbol warns you of danger!

- *Always follow the instructions to avoid injury to the user or damage to the product!*
-



EXPLOSION HAZARD!

This symbol warns you of an explosion hazard, which can be caused by excessive tyre pressure in a pneumatic tyre!

- *Always follow the instructions to avoid injury to the user or damage to the product!*
-



BURN HAZARD!

This symbol warns you of burns due to acid or other substances!

- *Always follow the instructions to avoid injury to the user or damage to the product!*
-



NOTE:

This symbol identifies general information which is intended to simplify working with your product and which refers to special functions.



Requirements:

- This symbol identifies a list of various tools, components and items which you will need in order to carry out certain work.
-

1.2 Type Classification and Area of Use

This vehicle has been classified as a mobility product in class B (for indoor and outdoor areas). It has been successfully tested for its safety according to German and international standards. When equipped with an appropriate lighting system, the vehicle is suitable for driving on public roads.

1.2.1 Permissible operating conditions

- **Surface:** The vehicle may be driven on a firm surface.
- **Splash water, rain, snow:** The vehicle was tested successfully for splash water insensitivity in compliance with EN60529 IPX4.
- **Operating temperature range** in compliance with ISO 7176-9: -25 to +50 °C
- **Storage temperature range** in compliance with ISO 7176-9: -40 to +65 °C

The vehicle is well suited to typical central European weather conditions.

1.2.2 Indications

The use of this mobility product is recommended for the following indications:

The inability or a greatly restricted ability to walk within the scope of the basic requirement to be able to move within one's own four walls. The need to leave the dwelling place in order to get some fresh air during a short walk or to reach those places generally to be found at close distance to the dwelling and where everyday business is carried out.

Provision of electric wheelchairs for interior and exterior areas is advisable if the use of hand-operated wheelchairs is no longer possible on account of the disability, yet proper operation of an electromotive drive unit is still practicable.



WARNING: Danger of injury to occupant and damage to wheelchair if driver is not mentally and physically able to keep full control of the vehicle at all times!

- *If necessary, operation of the Powerchair must be performed by an attendant!*
-

2 Safety Notes

- READ WELL BEFORE OPERATION!

2.1 General Safety Notes



Danger of injury if wheelchair is used in any other way than the purpose described in this manual!

- *Adhere strictly to the instructions in this User's Manual!*

Danger of injury if the wheelchair is driven when ability to operate a vehicle is impaired by medication or alcohol!

- *Never drive the wheelchair under the influence of medication or alcohol!*

Danger of damage or injury if wheelchair is accidentally set into motion!

- *Switch the wheelchair off before you get in, get out or handle unwieldy objects!*
 - *Be aware that there are only the motor brakes to stop your wheelchair. When the motors are disengaged, these brakes are automatically deactivated. For this reason, pushing the wheelchair by an attendant is only recommended on flat surfaces, never on gradients. Never leave your wheelchair on a gradient with its motors disengaged. Always re-engage the motors immediately after pushing the wheelchair.*
-



Danger of injury if the On/Off Button is pressed while the wheelchair is in motion, due to it coming to an abrupt, sharp stop!

- *If you have to brake in an emergency, simply release the joystick which will bring you to a halt!*

Danger of injury when transferring wheelchair to another vehicle for transport with the occupant seated in it!

- *It is always better to transfer the wheelchair to another vehicle without the occupant seated in it!*
- *In case the wheelchair does need to be transferred to another vehicle over a ramp with the occupant seated in it, always have an attendant stand behind the wheelchair during transfer to ensure it does not tip over backwards!*

Danger of injury, if the wheelchair is used as a vehicle seat without a special restraining system!

- *Only ever use the wheelchair as a vehicle seat in connection with a Wheelchair Restraint System and with the safety belts of the transporting vehicle! Make sure to follow the instructions and recommendations issued by the Restraint System's manufacturer!*

Danger of injury if maximum permissible load is exceeded!

- *Do not exceed the maximum permissible load (see technical specifications)!*
-



Danger of injury due to wrong lifting or dropping of heavy components!

- *When maintaining, servicing or lifting any part of your wheelchair, take into account the weight of the individual components especially the batteries! Be sure at all times to adopt the correct lifting posture and ask for assistance if necessary!*

Danger of falling out of the wheelchair.

- *Do not slide forward on the seat, do not lean forward between your knees, do not lean backwards out over the top of the backrest, for example to reach an object.*
- *If restraining systems are installed (such as seat belts), use them each time you drive the wheelchair.*
- *When changing over to a new seat, position the wheelchair as close as possible to the new seat.*

Danger of injury by moving parts!

- *Make sure that no injury is incurred by moving parts of the wheelchair, like wheels or one of the Lifter Modules (if fitted), especially when children are around!*

Danger of fire or breaking down due to electric devices being connected!

- *Do not connect any electric devices to your wheelchair that are not expressly certified by Invacare® for this purpose! Have all electrical installations done by your authorised Invacare® Dealer!*
-

2.2 Safety Information on Electromagnetic Interference

This electric vehicle was successfully tested in accordance with International standards as to its compliance with Electromagnetic Interference (EMI) Regulations. However, electromagnetic fields, such as those generated by radio and television transmitters, and cellular phones, can influence the functions of electric vehicles. Also, the electronics used in our vehicles can generate a low level of electromagnetic interference, which however will remain within the tolerance permitted by law. For these reasons we ask you to please observe the following precautions:



WARNING: Danger of malfunction due to electromagnetic interference!

- *Do not switch on or operate portable transceivers or communication devices (such as radio transceivers or cellular phones) when the vehicle is switched on!*
 - *Avoid getting near strong radio and television transmitters!*
 - *In case the vehicle should be set in motion unintentionally or the brakes are released, switch it off immediately!*
 - *Adding electrical accessories and other components or modifying the vehicle in any way can make it susceptible to electromagnetic interference. Keep in mind that there is no sure way to determine the effect such modifications will have on the overall immunity of the electronic system!*
 - *Report all occurrences of unintentional movement of the vehicle, or release of the electric brakes to the manufacturer!*
-

2.3 Safety Information on Driving and Freewheel Mode



Danger of injury if the wheelchair tips over!

- *Only ever negotiate gradients up to the maximum tilt-resistant gradient (see Technical Specifications) and only with the backrest and seat tilt in an upright position!*
 - *Only ever drive downhill at a maximum of 2/3 of the top speed! Avoid abrupt braking or accelerating on gradients!*
 - *If at all possible, avoid driving on slippery surfaces (such as snow, gravel, ice etc.) where there is a danger of you losing control over the vehicle, especially on a gradient! If driving on such a surface is inevitable, then always drive slowly and with the utmost caution!*
 - *Never attempt to overcome an obstacle when on an uphill or downhill gradient!*
 - *Never attempt to drive up or down a flight of steps with your wheelchair!*
 - *Always approach obstacles straight on! Ensure that the front wheels and rear wheels move over the obstacle in one stroke, do not stop halfway! Do not exceed the maximum obstacle height (see Technical Specifications)!*
 - *Avoid shifting your centre of gravity as well as abrupt joystick movements and changes of direction when the wheelchair is in motion!*
 - *Never use the wheelchair to transport more than one person!*
 - *Do not exceed the maximum permissible load!*
 - *Note that the wheelchair will brake or accelerate if you change the Driving Mode whilst the wheelchair is in motion!*
-



Danger of breaking down in adverse weather conditions, i.e. extreme cold, in an isolated area!

- *If you are a user with severely limited mobility, we advise that in the case of adverse weather conditions DO NOT attempt a journey without an accompanying attendant!*

Danger of injury if your foot slides off the footrest and gets caught underneath the wheelchair when it is in motion!

- *Make sure each time before you drive the wheelchair that your feet are squarely and securely in place on the footplates, and that both legrests are properly locked into place!*

Danger of injury if you collide with an obstacle when driving through narrow passages such as doorways and entrances!

- *Drive through narrow passages in the lowest Driving Mode and with due caution!*
-

2.4 Safety Information on Wheelchairs with a Lifter



IMPORTANT - IF YOUR WHEELCHAIR IS EQUIPPED WITH A LIFTER:

Danger of injury if the wheelchair tips over!

- *Never exceed the maximum permissible load (see Technical Specifications)!*
- *Avoid dangerous driving situations when the lifter is in a raised position, such as trying to overcome obstacles like kerbs or driving up or down steep gradients!*
- *Never lean out of the seat when the lifter is raised!*
- *Inspect the lifter module at least once a month to make sure the automatic speed reduction function, which reduces the speed of the wheelchair when the lifter is raised, is working properly (see chapter on lifter)! Notify your authorised dealership immediately if it is not working properly!*

Danger of injury by moving parts!

- *Never let objects get caught in the space underneath a raised lifter!*
- *Make sure that neither you nor anyone else is injured by placing hands, feet other body extremities under the raised seat!*

Danger of malfunction of the Lifter Module!

- *Inspect the lifter module at regular intervals to make sure there are no foreign objects or visible damage, and to make sure the electric plugs are firmly inserted into their sockets!*
-

2.5 Safety Information on Wheelchairs with Recaro Seats



Danger of injury if the wheelchair tips over!

The centre of gravity of a Recaro seat is higher than that of other seats. The Recaro seat is also heavier than other seating systems. The backrests of RECARO seats can be leaned back 90°. For these reasons there is an increased risk of tipping over!

- *Never lean the backrest backward more than 45° degrees, and never exceed 15° when driving the wheelchair!*



**More than 45°
NEVER!!**



**15°-45°
Standstill!!**



**0°-15°
Driving**

3 Key features

- 1) Headrest (adjustment clamping lever is located behind the headrest)
- 2) Slide grip
- 3) Backrest
- 4) Knob for adjusting armrest angle
- 5) Disengaging lever
- 6) Drive wheel
- 7) Armrest
- 8) Remote
- 9) Legrests



4 Getting in and out of the wheelchair



Important information when side transferring in and out of the wheelchair

In order to side transfer it is necessary for the armrest to either be raised or removed completely depending on the model. A skirtguard can be installed as an option in connection with the parallel sliding armrest. This is attached in the same way as the standard armrest and must also be removed when transferring.

4.1 Remove the standard armrest in order to side transfer

Removing the armrest:

- Loosen remote cable (1) from remote.
- Loosen clamping lever (2)
- Remove the side panel from the receptacle

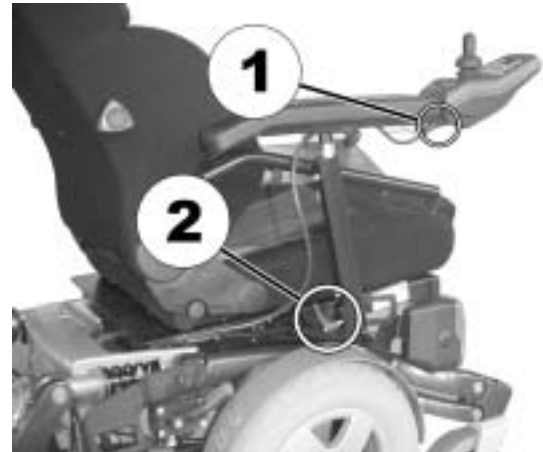

4.2 Raise the parallel sliding armrest / remove the skirtguard (optional)

Swivel up armrest

- Swivel armrest up to access from the side.



Removing the skirtguard (optional) to get on:

- Loosen clamping lever (1)
- Remove the skirtguard from the receptacle.



Getting into the wheelchair:

- Position your wheelchair as close as possible to your seat. This might have to be done by an attendant.
- Switch your wheelchair off.
- Apply the hand brake of your wheelchair (if existing).
- Detach the side part of your wheelchair or swivel it up.
- Now slide into the wheelchair.

**Getting out of the wheelchair:**

- Drive your wheelchair as close as possible to your seat.
- Switch your wheelchair off.
- Apply the hand brake of your wheelchair (if existing).
- Detach the side part of your wheelchair or swivel it up.
- Now slide onto your new seat.



NOTE:

If you do not have sufficient muscle strength, you should ask other persons for help. Use a sliding board, if possible.

5 Driving

5.1 Before driving for the first time...

Before you take your first trip, you should familiarise yourself well with the operation of the vehicle and with all operating elements. Take your time to test all functions and driving modes.



NOTE:

If installed, use the restraining systems (seat belts) each time you use the vehicle.

Sitting Comfortably = Driving Safely

Before each trip, make sure that:

- **You are within easy reach of all operating controls.**
- **The battery charge is sufficient for the distance intended to be covered.**
- **The seatbelt is in perfect order.**

5.2 Taking Obstacles

5.2.1 The "SureStep" System

The Invacare® Typhoon is fitted with "SureStep" technology. When climbing over obstacles, the front steering wheels are raised using the torque generated by the drive wheels.

Please note that the techniques required for overcoming obstacles for wheelchairs fitted with central drives and "SureStep" technology is completely different to that required for models with front wheel or rear wheel drive.

5.2.2 The "Stability Lock" System

If your wheelchair is fitted with a lifter and this is raised, this will restrict the function of the "SureStep" system due to the "Stability Lock". The "Stability Lock" increases the tilt stability of the wheelchair and prevents front wheel spring deflection on the "Walking Beams" when braking or when descending slopes.

5.2.3 The components of the "SureStep" and the "Stability Lock" system

The diagram below shows the components in the "SureStep" system with the side panels removed. (1) Anti-Dive Spring, (2) Walking Beam und (3) Stability Lock.



5.2.4 Maximum obstacle height

Your wheelchair can overcome obstacles and kerbs with the following heights.

- 10 cm

5.2.5 Safety information when ascending obstacles



CAUTION: Danger of Tipping Over!

- *Never approach obstacles at an angle!*
 - *Put your backrest into an upright position before climbing an obstacle!*
-



CAUTION: The wheelchair can be damaged if an obstacle is approached at excessive speed.

- *Always approach obstacles at low speed! As soon as the front wheels come into contact with the obstacle, stop for a short period before driving over the obstacle! Wheelchairs fitted with centre drive have a special mechanism (Walking Beam) for overcoming obstacles. Approaching at speed can actually lead to mechanical damage.*
-

5.2.6 Safety information when descending obstacles



CAUTION: The wheelchair can tip over to the front when descending from an obstacle that is too high as there can be spring deflection of the front swivel wheels.

- *Please pay particular attention to tilt resistance when driving down off an obstacle!*
 - *If available, please set your seat tilt to a greater value than normal!*
 - *The maximum obstacle height refers to ascent as well as descent. Never descend from obstacles that are higher than those you may ascend!*
-

5.2.7 The correct way to overcome obstacles



CAUTION: If the lifter is raised, the drive wheels can lose ground contact when descending from obstacles or driving on an uneven surface! The "Stability Lock" prevents "Walking Beam" spring deflection when the lifter is raised!

- *Never descend from obstacles when the lifter is raised or drive on an uneven surface!*
 - *In the event of the drive wheels losing ground contact, the lifter must be lowered so that the drive wheels come into contact with the ground again.*
-

Ascending and descending

The same approach applies to both ascending and descending obstacles:

- Approach the obstacle or the kerb slowly and at a right angle.
- Stop shortly before the front wheels come into contact with the obstacle.
- Check the position of the front wheels. They must be in driving direction and vertical to the obstacle!
- Approach slowly and keep at a consistent speed until the rear wheels have also passed over the obstacle.

Right



Wrong



5.3 Driving up and down gradients

The Invacare® Typhoon has a maximum hill-climbing ability without overturning of 20%.



WARNING: Danger of tipping over!

- *Only ever drive downhill at a maximum of 2/3 of the top speed!*
 - *Avoid sudden changes of direction or abrupt braking when driving on slopes!*
 - *Always return the backrest of your seat or the seat tilt to an upright position before ascending slopes! We recommend that you position the seat backrest or the seat tilt slightly to the rear before descending slopes!*
 - *If the lifter is raised drive mode is only used for positioning and not for regular drive operation! Lower the lifter before ascending a slope!*
 - *Never attempt to ascend or descend a slope on slippery surfaces or where there is a danger of skidding (such as wet pavement, ice etc)!*
 - *Avoid trying to get out of the vehicle on an incline or a gradient!*
 - *Always drive straight in the direction the road or path you are on goes, rather than attempting to zigzag!*
 - *Never attempt to turn around on an incline or a slope!*
-

5.4 Parking and stationary

When parking your vehicle or if your vehicle is stationary for a prolonged period:

- Switch the vehicle's power system off (ON-/OFF key).
- Activate your anti-theft lock, if existing.

6 Pushing the wheelchair by hand

The motors of the wheelchair are equipped with automatic brakes, preventing that the wheelchair starts rolling out of control when the joystick box is switched off. When pushing the wheelchair, the magnetic brakes must be disengaged.

6.1 Manually disengaging conventional motors



Danger of the vehicle running away!

- *When the motors are disengaged (for push operation), the electromagnetic motor brakes are deactivated! When the vehicle is parked, the levers for engaging and disengaging the motors must without fail be locked firmly into the "DRIVE" position (electromagnetic motor brakes activated)!*
-

The lever for disengaging the motors is on the rear right side on the wheelchair chassis.

Disengaging motors:

- Switch off remote.
- Pull the locking pin (1) downwards. Pull the engaging lever (2) to the rear. The motors are now disengaged.

Re-engaging motors

- Push the engaging lever (1) forwards. The motors are now re-engaged.

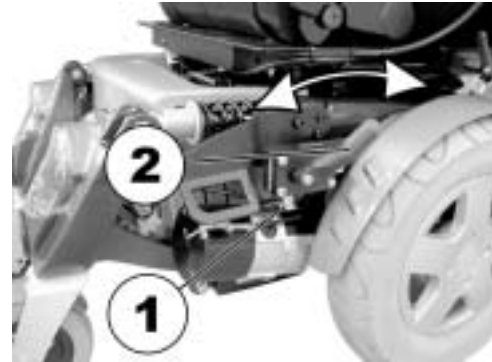

6.2 Electrically disengaging GB motors



CAUTION! Danger of the wheelchair rolling away!

- *The motor brakes do not function in disengaged condition (push mode)! The pushbutton for disengaging the motors must never be fixed in its pushed-in position using adhesive tape etc!*
-

The pushbutton for disengaging the motors is located on the push handle.

Disengaging motors:

- Press key (1). A peep tone will sound for about one second. The motors remain disengaged until a key is pressed (if you cannot hear the peep tone, or the peep tone stops after around one second, there is an error. In this case please contact your dealer.).

Re-engaging motors

- Release key (1) again. The motors are now re-engaged.



6.3 Manually disengaging GB motors (emergency disengaging)



Danger of the vehicle running away!

- *When the motors are disengaged (for push operation), the electromagnetic motor brakes are deactivated! When the vehicle is parked, the levers for engaging and disengaging the motors must without fail be locked firmly into the "DRIVE" position (electromagnetic motor brakes activated)!*
-

The lever for disengaging the motors is located behind the right-hand drive wheel.

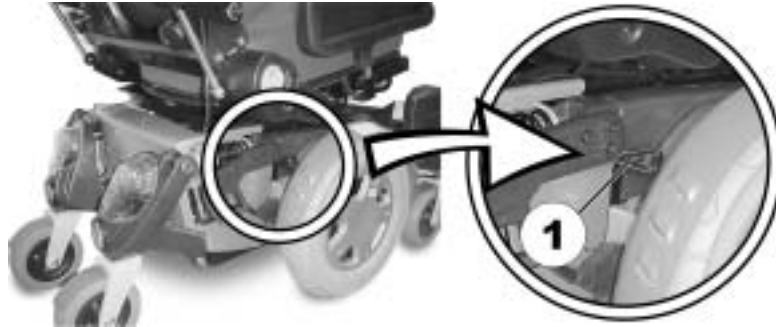

Disengaging motors:

- Switch off remote.
- Pull the engaging lever (1) to the rear. The motors are now disengaged.

Re-engaging motors

- Push the engaging lever (1) forwards. The motors are now re-engaged.

7 The REM 24 SD Remote

7.1 Layout of the remote

Upper side

Controls

- 1) Immobilizer
- 2) "Activate / scroll through drive mode" button
- 3) Horn
- 4) Left-hand indicator
- 5) Joystick
- 6) "Activate / scroll through adjustment mode" button
- 7) ON/OFF button
- 8) Light
- 9) Right-hand indicator
- 10) Hazard warning signal flasher



Upper side

Displays

- 11) Battery charger display
- 12) Status display (in key symbol)
- 13) Drive mode display
- 14) Left-hand indicator display
- 15) Hazard warning signal flasher display
- 16) Light display
- 17) Right-hand indicator display



Underside

- 1) Charger socket
- 2) Programming socket



Rear panel

- 1) Socket for Buddy button 1 (corresponds to "Activate / scroll through drive mode" button).
- 2) Socket for Buddy button 2 (corresponds to "ON/OFF" button)
- 3) Socket for Buddy button 3 (corresponds to "Activate / scroll through adjustment mode" button).
- 4) Socket for bus cable



7.2 ON/OFF diode (status display)



INFORMATION

The ON/OFF diode (in key symbol) also serves as status or error message display. For error codes please see chapter "**Error codes and diagnostic codes**" on page 46.

7.3 Battery charger display

- All diodes illuminated: **Full range**
- Only red diodes illuminated:
Reduced range
- Both red diodes flashing:
Very low range
- Only one red diode flashing:
Battery on reserve = Charge batteries straight away

Battery charger display



INFORMATION

Protection against total discharge: The electronic system automatically shuts actuation down after a certain travel time on reserve battery and the wheelchair comes to a standstill.

7.4 Activating / deactivating the immobilizer

Activating the immobilizer

- Switch on the remote.
- Use the end of the magnetic key (Invacare® Logo) to move over the sensor area (1) on the remote (key symbol). The horn will sound briefly once. The remote shuts down automatically. The immobilizer is activated.

Deactivating the immobilizer

- Switch on the remote. The status display will flash red slowly.
- Use the end of the magnetic key (Invacare® Logo) to move over the sensor area (1) on the remote (key symbol).

Immobilizer



Magnetic key



7.5 Using the Buddy buttons with the remote



What is a Buddy button?

A Buddy button is an additional sensing device that can be used to activate a remote function. The sockets for Buddy buttons are to be found at the rear of the remote.

- 1) Socket 1 (corresponds to the "Activate / scroll through drive mode" button).
- 2) Socket 2 (corresponds to the "ON/OFF" button)
- 3) Socket 3 (corresponds to the "Activate / scroll through adjustment mode" button).



7.6 Controlling the wheelchair using the remote

- Switch on the remote (ON/OFF button). The displays on the remote will illuminate. The wheelchair is ready to drive.
- Set the drive level ("drive level" button see "**Layout of the remote**" on page 34).
- Speed stage 1 (slow) to 5 (fast) is shown on the drive level display.



Can the electronic system programming be adapted?

The electronic controller is programmed with standard values during manufacture. Your Invacare® dealer can carry out programming tailored to fit your requirements.



Will the wheelchair not drive after switching on?

Check the drive-away lock (see chapter "**Activating / deactivating the immobilizer**" on page 38) and the status bar indicator (see chapter "**ON/OFF diode (status display)**" on page 37.).

7.6.1 How a wheelchair with "Indirect Steering" reacts to joystick movements.

"Indirect Steering" occurs by individually applying power to the drive wheels, and is found on wheelchairs with front, rear and middle wheel drive.

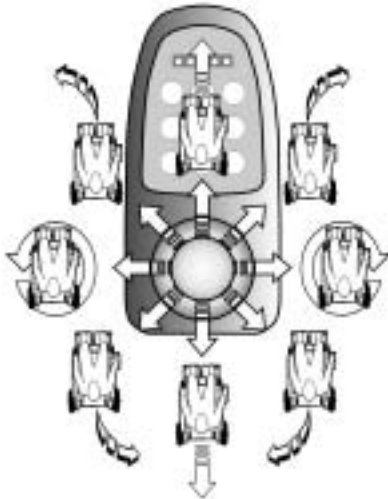

Travel direction

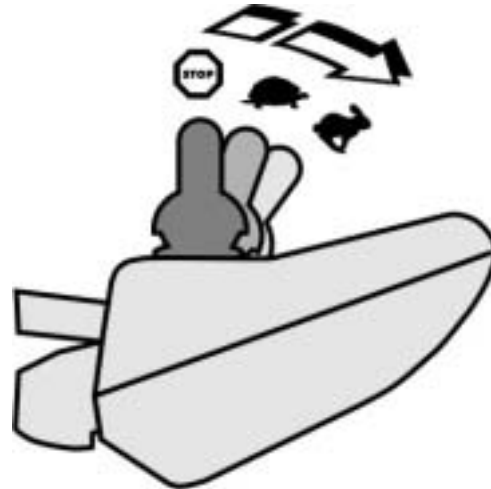

The further the joystick is moved in a particular direction, the more dynamically the wheelchair reacts.



Note:

To brake quickly, simply let go of the joystick. It will then automatically return to the middle position. The wheelchair will brake.

7.7 Operating the electric adjustment options

Electric adjustment options, like electric legrests or an electric backrest, are operated by using the joystick.

7.7.1 Activating adjustment mode

- Press the "activate / scroll through adjustment mode" button (A). The remote switches to the adjustment mode last used. The driving mode display (B) switches to the appropriate symbol (one of the symbols shown below).



Seat tilt



Backrest



Left legrest



Right legrest



Both legrests



Lifter



Information:

When using the REM 24 SD remote it is not necessary – as on previous remote versions – to push the joystick forward in order to access the adjustment mode. It is sufficient to operate the adjustment mode button just once.

If the remote has been programmed appropriately, further modes can be accessed by repeatedly pressing the adjustment mode button, i.e. light mode or ECU mode (environment control unit).

The standard REM 24 SD programming only supports the adjustment function. Please speak to your Invacare dealer if you have any questions in this respect.

7.7.2 Selecting and operating the adjustment option

- Move the joystick to the left or right = Select adjustment option on the submenu (A).
- Move the joystick forward/backward = Operate adjustment option (B).



7.7.3 Changing back to driving mode

- Briefly press the "Activate / scroll through driving mode" button (A). The remote switches back to the driving mode last used. The driving mode display indicates the drive level (B).

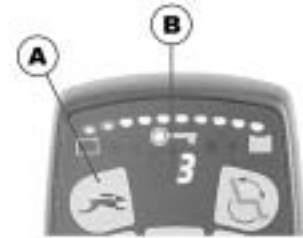

7.8 Error diagnosis

In the event that the electronics should show signs of failure, please consult the following troubleshooting guide in order to locate the error.



INFORMATION

Before beginning with the diagnosis, please ensure that the drive electronics are switched on.

If the status display is OFF:

Please check whether the drive electronics are SWITCHED ON.

Please check whether all cables have been connected correctly.

Please ensure that the batteries are not discharged.

If the status display is FLASHING:

Please count the number of flashing sequences and move on to the next section.

If the red diodes on the battery charger display and the status display are FLASHING, Drive mode display shows a horizontal bar:

Battery discharged. Please charge the battery.

7.8.1 Error codes and diagnostic codes

The drive electronics are capable of rectifying some errors automatically. In this case the status display will cease to flash. Please switch the remote on and off several times. Wait approx. 5 seconds each time before switching the remote on again. If this does not rectify the error, locate the error using the flash codes shown below.

FLASH CODE	FAULT	IMMEDIATE MEASURE	FURTHER HELP
1	Module defective.	-	• Consult dealer.
2	Lifter raised or lowered too far (seat not at driving height)	• If lifter is raised, lower in stages until the status display stops flashing. If lowered too far, raise lifter in stages until the status display stops flashing. If at all possible, only drive when the seat is at driving height.	-
	Accessory error.	-	• Consult dealer.
3	Error on right motor. Connection loose/faulty.	• Check plug-in connectors.	• Consult dealer.
4	Error on left motor. Connection loose/faulty or motor faulty.	• Check plug-in connectors.	• Consult dealer.

FLASH CODE	FAULT	IMMEDIATE MEASURE	FURTHER HELP
5	Error/brake error on right motor. Connection loose/faulty or motor faulty.	<ul style="list-style-type: none"> • Check plug-in connectors. 	<ul style="list-style-type: none"> • Consult dealer.
	Motors uncoupled	<ul style="list-style-type: none"> • Couple motors. Switch remote off and on again. 	-
6	Error/brake error on left motor. Connection loose/faulty or motor faulty.	<ul style="list-style-type: none"> • Check plug-in connectors. 	<ul style="list-style-type: none"> • Consult dealer.
7	Battery totally discharged.	<ul style="list-style-type: none"> • Charge battery 	<ul style="list-style-type: none"> • Consult dealer.
8	Battery voltage too high.	-	<ul style="list-style-type: none"> • Consult dealer.
9 or 10	Faulty data transmission between modules.	-	<ul style="list-style-type: none"> • Consult dealer.
11	Motors overstressed.	<ul style="list-style-type: none"> • Switch remote off and on again 	-
12	Compatibility problems between the modules.	-	<ul style="list-style-type: none"> • Consult dealer.

8 Adjusting the wheelchair to the user's seating posture



CAUTION: Wheelchair damage and risk of accident! Collisions can occur between the legrest and the chassis or between the foot plates and the ground in the event of varying adjustment option combinations! This occurs in particular on wheelchairs with lifter and a seat angle adjustment range of -10° to $+35^{\circ}$!

- *When adjusting seat angle, lifter and legrest please ensure that the legrest does not collide with the wheelchair chassis or the foot plates with the ground.*
-

8.1 Recaro® seats



Recaro® Seats

For more information on the different manual adjustment options on Recaro® Seats, please see the User Manual that comes with your Recaro® Seat.

8.2 Adjusting the armrests and the joystick box

8.2.1 Adapting the remote to the length of the user's arm



Requirements:

- Allen key 3 mm
-

- Loosen the socket head screw (1).
- Set remote to the desired length by pushing forward or backward.
- Tighten screw.

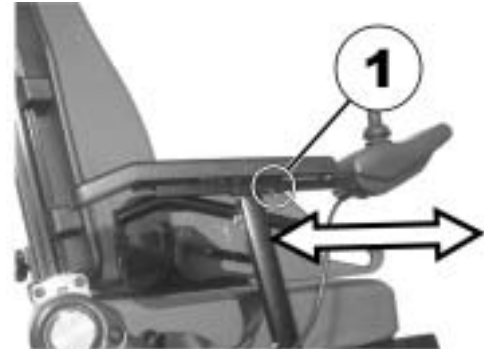

8.2.2 Setting the height of the remote

- Loosen one or both of the wing screws (1 and 2) that allow height adjustment of the joystick box.
- Adjust the joystick box to the desired height.
- Re-tighten the screw(s).

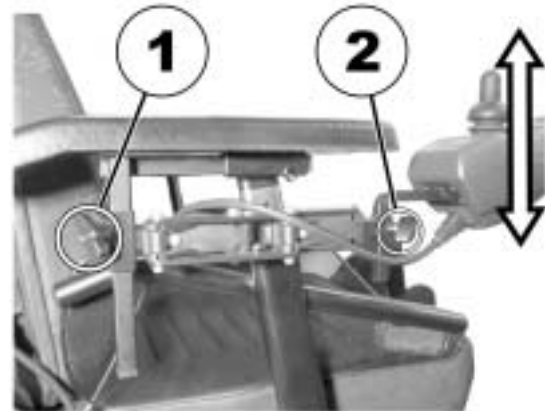

8.2.3 Setting the height of the armrests

- Loosen the release handle (1).
- Set the armrest at the desired height.
- Tighten the release handle.



8.2.4 Setting the width of the armrests

The distance between the armrests can be adjusted by 5.5 cm on both sides (totalling 11 cm).



Requirements:

- Allen key 8 mm
-

Where to find the adjustment screws

The figure below shows the position of the screw (1) which allows armrest width adjustment (only the left side is shown in the illustration).

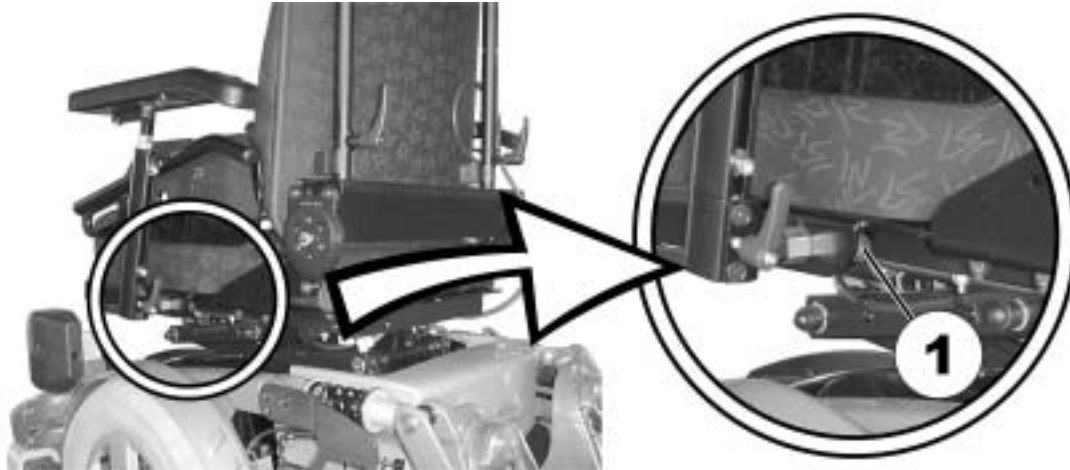

Doing the adjustment

- Loosen screw (1)
- Adjust armrest to required position.
- Retighten the screw.
- Repeat this procedure for the second armrest.



8.3 Manually adjusting the seat tilt

The manual seat angle adjustment has an adjustable range of 0° to 15°.

The seat angle is adjusted by means of a spindle, which is to be found at the front underneath the seat frame.

When adjusting the seat angle it should be ensured that at least 1 cm of the threaded bolt always remains inside the spindle and is not completely unscrewed from the spindle.



NOTE

It is easier to adjust the angle of the seat when there is nobody sitting in the wheelchair.

The figure to the right shows the position of the spindle (1) for manual seat angle adjustment.



- Loosen the counternut (1) on the spindle.
- Set the seat angle by turning the spindle (2).
- Tighten the counternut.

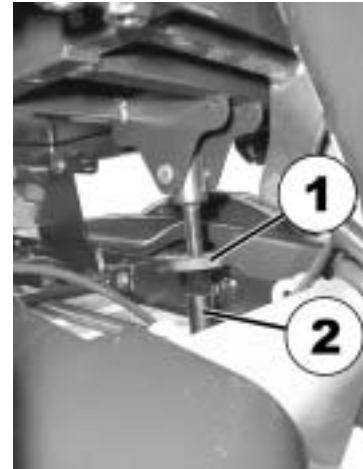

8.4 Manually adjusting the backrest

8.4.1 Adjusting the backrest using the gas pressure spring

The lever for adjusting the backrest is located on the opposite side from the Joystick Box under the armrest.

The angle can be adjusted continuously between 0° and 30°.

Adjusting angle of the backrest

- Pull lever (1) upward.
- Adjust backrest angle by leaning forward or backward.
- Release the lever again. The backrest is locked at the desired angle.



NOTE

If the lever is pulled upwards and inwards at the same time, it will latch into a notch at the top. Push the lever out of the notch to release it, and allow it to be moved down again.

8.4.1.1 Adjust the backrest using the perforated plate

The angle of the backrest has six positions, from -10° to $+30^{\circ}$.

- Unscrew the hand screws (1) on both sides.
- The backrest is adjusted by choosing a combination of one of the two bore holes in the backrest frame and one of the six bore holes in the fixing plate.
- Re-position the screws and tighten.



8.4.2 Flex and Contour Seats

- Set the angle by turning the hand wheel (1).



8.5 The Lifter

The electric lifter is operated via the remote. Please see chapter "**Operating the electric adjustment options**" on page 42.



Please note – Speed restriction

The lifter is equipped with sensors that reduce the drive speed of the wheelchair as soon as the lifter is raised or lowered above a certain point.

This is in order to guarantee the tilt stability of the wheelchair or in order to avoid damage to the legrests.

When speed restriction is activated an appropriate blinking code is displayed on the remote. Please see chapter "**ON/OFF diode (status display)**" on page 37 and chapter "**Error codes and diagnostic codes**" on page 46.

In order to revert to normal drive speed move the lifter to drive height: Raise the lifter slowly if the lifter has been lowered. If the lifter has been raised, lower the lifter until the status display stops blinking.

8.5.1 Explanation of symbols on lifter warning sticker.



Do not lean out when the lifter is raised!



Do not drive up or down slopes when the lifter is raised!



Do not allow any body parts to get under a raised seat!



Never drive with two people!



Never drive over uneven surfaces when the lifter is raised!

8.6 Legrests

8.6.1 Electric legrest

The electric legrest is operated via the remote. Please see chapter "**Operating the electric adjustment options**" on page 42.

The electric legrest can be lowered completely to assist getting out of the wheelchair. To do so, move your seat into the correct position by lowering the lifter or by means of a negative seat angle (tilted slightly to the front).

8.6.1.1 Completely lowering electrical legrests as dismounting aid

The lever for unlocking the legrests is located either right or left of the seat frame at the front.

- Pull lever (1). The legrests will lower.



Information

It is sufficient to pull the lever to release the legrest whilst the legrest is not in use (feet are not on the foot plates) in order to lift the legrest into drive position again.

8.6.2 Adjustable legrest

8.6.2.1 Adjusting the angle



Prerequisites:

- 1x 10 mm open-ended spanner
-

- Use the open-ended spanner to loosen the counternut (1).
- Move the legrest to the desired position by turning the spindle (2).
- Tighten the counternut.



8.6.2.2 Adjusting the length of the legrest



Prerequisites:

- 1x 5 mm socket head spanner
-
- Use the socket head spanner to loosen the fastening screws (1).
 - Slide the foot support to the desired height.
 - Tighten the fastening screws.

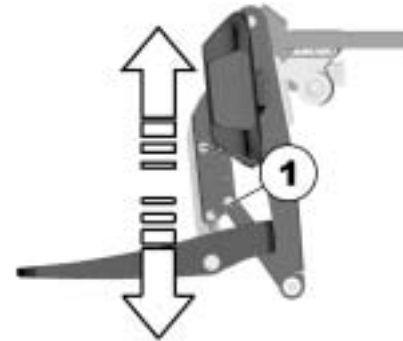

8.6.2.3 Adjusting the calf plate to the calf width of the user

The calf plate of the legrest can be adapted to the user's calf width by bending apart or together.

- Bending the calf plate to the desired width.



8.6.2.4 Adjusting the angle of the foot plate



Prerequisites:

- 1x 5 mm socket head spanner
-
- Fold up the foot plates in order to access the adjusting screws.
 - Use the socket head spanner to adjust the adjusting screws (1).
 - Fold the foot plate down again.



9 Electrical System

9.1 Electronics Protection System

The vehicle's electronics are equipped with an overload-protection system.

If the motors are put under considerable strain for a longer period of time (for example, when driving up a steep hill) and especially when the ambient temperature is high, then the electronic system could overheat. In this case the vehicle's power is reduced gradually until it finally comes to a halt. The Status Display shows a corresponding error code. By switching the power supply off and back on again, the error code is cancelled and the electronics are switched back on. It will take approximately five minutes until the electronics have cooled down enough for the motors to restore full power again.

When the motors are stalled by an insurmountable obstacle, such as a high kerb, and the vehicle driver allows the motors to strain against this hindrance for more than 20 seconds without moving, then the electronics will automatically switch off to prevent the motors from being damaged. The Status Display shows a corresponding error code. By switching off and back on again, the error code is cancelled and the electronics are switched back on.

9.1.1 The main fuse



NOTE

A defective main fuse may be replaced only after checking the entire electric system. An Invacare® specialised dealer must perform the replacement.

All electrical equipment fitted to the wheelchair is protected against overload by the main fuse.

The main fuse is located beneath the rear central panel to the left of the power module.

In order to access the main fuse, you must first remove the rear central panel.



9.2 Batteries

9.2.1 What you need to know about batteries

Power is supplied by two 12V gel batteries. The batteries are maintenance-free and only need regular charging.

New batteries should always be fully charged once before their first use. New batteries will be at their full capacity after having run through approx. 10 - 20 charging cycles. How fast the batteries will be discharged will depend on many circumstances, such as ambient temperature, condition of the surface of the road, tyre pressure, weight of the driver, way of driving and utilisation of lighting, etc.



NOTE

Gel batteries are not hazardous goods. This classification is based on the German *GGVS Hazardous Goods Road Transport Ordinances*, and the *IATA/DGR Hazardous Goods Rail Transport / Air Transport Ordinances*. Gel batteries may be transported without restrictions, whether by road, rail or by air. Individual transport companies have, however, guidelines which can possibly restrict or forbid certain transport procedures. Please ask the transport company regarding each individual case.

Pay attention to the Battery Charge Indicator! Make sure to charge the batteries when the Battery Charge Indicator shows that battery charge is low. We recommend charging the batteries after each trip, as well as each night over night. Depending on the level of discharge, it can take up to 12 hours until the batteries are fully charged again.

Protect your charger from sources of heat such as heaters and direct sunlight. If the battery charger overheats, charging current will be reduced and the charging process delayed.

To avoid damaging the batteries, never allow them to be fully discharged. Do not drive on heavily discharged batteries if it is not absolutely necessary, as this will strain the batteries unduly and shorten their life expectancy.

In case your vehicle is not used for a longer period of time, then the batteries must be charged at least once a month to maintain a full charge. Alternatively, the vehicle can stay connected to the charger. The batteries cannot be overcharged with the specified charger.

Please use only charging devices in Class 2. This class of chargers may be left unattended during charging. All charging devices which are supplied by Invacare® and comply with these requirements.

9.2.2 Charging the batteries

- Make sure you read and understand the battery charger's User's Manual, if supplied, as well as the safety notes on the front and rear panels of the charger!



WARNING:

Danger of explosion and destruction of batteries if the wrong battery charger is used!

- *Only ever use the battery charger supplied with your vehicle, or a charger that has been approved by Invacare®!*

Danger of electric shock and damage to the battery charger if it is allowed to get wet!

- *Protect the battery charger from water!*
- *Always charge in a dry environment!*

Danger of short circuit and electric shock if the battery charger has been damaged!

- *Do not use the battery charger if it has been dropped or damaged!*

Danger of fire and electric shock if a damaged extension cable is used!

- *Only ever use an extension cable if it is absolutely necessary! In case you must use one, make sure it is in good condition!*
-

Charging the batteries

- Switch off the wheelchair at the Joystick Box.
- Connect the battery charger to the Joystick Box - the charging socket is located on the bottom of the Joystick Box (1).
- Connect battery charger to the mains outlet and switch on if necessary.
- After charging is complete, first disconnect the battery charger from the mains supply, then disconnect from the Joystick Box.



9.2.3 Removing and fitting batteries



WARNING:

Danger of injury if the batteries are not handled correctly during assembly and maintenance work!

- *New batteries should be installed by authorised technicians!*
- *Observe the warnings on the batteries!*
- *Take into account the heavy weight of the batteries!*
- *Only ever use the battery type defined in the technical specifications!*

Danger of fire and burns if battery terminals are short-circuited!

- *DO NOT short-circuit battery terminals with a tool!*
-



WARNING:

Corrosion and burns from acid leakage if batteries are damaged!

- *Remove clothes that have been soiled by acid immediately!*

After contact with skin:

- *Immediately wash affected area with lots of water!*

After contact with eyes:

- *Immediately rinse eyes under running water for several minutes; consult a physician!*
-

9.2.3.1 Removing the batteries



CAUTION: Risk of fire and burns if battery poles are bridged!

- *When replacing the batteries the battery poles MUST NOT come into contact with metal parts of the wheelchair causing bridging.*
 - *Be sure to replace the battery pole caps after the batteries have been replaced.*
-

**Requirements:**

- 6mm Allen key
 - 5 mm Allen key
 - Needle-nosed pliers
-
- If lifter is fitted, pull the seat unit upward until the engaging mechanism (1) is heard to lock in place.

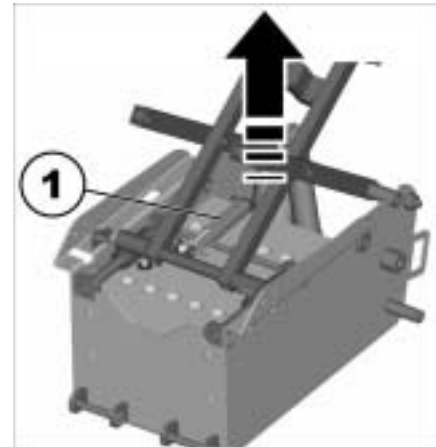

- Use the 6mm Allen key to loosen and remove the screws (1) on both sides.

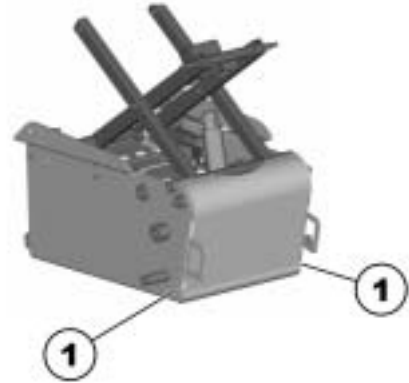

- Pull cover to the front and remove.



- Remove the locking clip (1) using the needle-nosed pliers and pull out the retaining pin of the actuator or spindle retainer (on manual seat angle adjustment) (2)

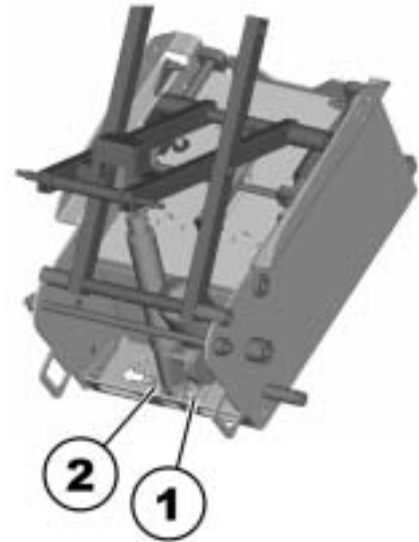

- Use the 5mm Allen key to loosen and remove the screws (1) on both sides.
- Pull the holding plate to the front and remove.

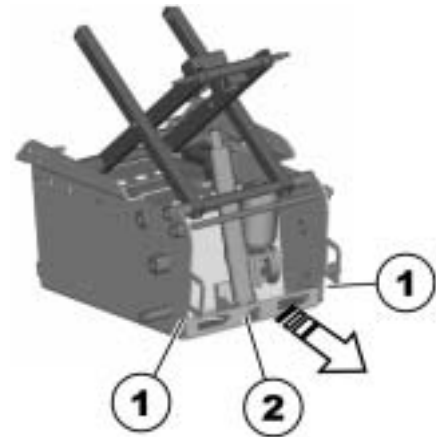

- Pull out the actuator or spindle (on manual seat angle adjustment) (1) to the front.



- Release and remove the battery cable on the battery poles.

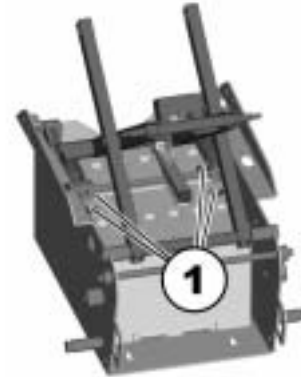

- Remove batteries by pulling to the front.

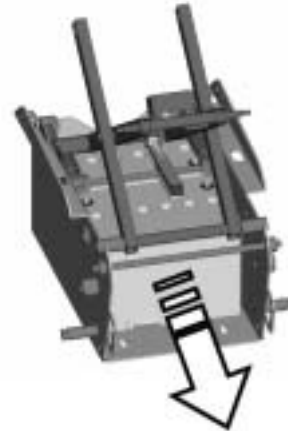



NOTE

Installation of new batteries is carried out in reverse order.

Releasing the lifter locking mechanism

- If lifter is fitted raise the piston rod of the actuator carefully on the remote until the piston head (1) interlocks in the retainer track (2). The lifter is now supported by the actuator.

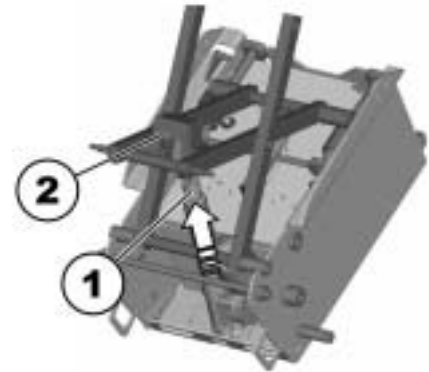

- Pull the engaging mechanism lever (1) upward. The engaging mechanism is now released again.

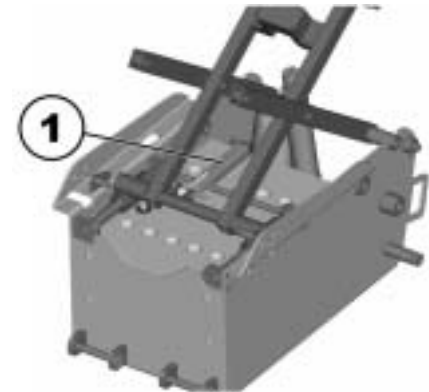

9.2.3.2 How to handle damaged batteries correctly



WARNING:

Corrosion and burns from acid leakage if batteries are damaged!

- *Remove clothes that have been soiled by acid immediately!*

After contact with skin:

- *Immediately wash affected area with lots of water!*

After contact with eyes:

- *Immediately rinse eyes under running water for several minutes; consult a physician!*
-



Requirements:

- Safety goggles
 - Acid-resistant gloves
 - Acid-resistant receptacle for transportation
-

- Always wear appropriate safety clothing when handling damaged batteries.
- Place damaged batteries in an acid-resistant receptacle immediately after removing them.
- Only ever transport damaged batteries in an appropriate acid-resistant receptacle.
- Wash all objects that have come into contact with acid with lots of water.

Disposing of dead or damaged batteries correctly

Dead or damaged batteries can be given back to your dealer or directly to Invacare®.

10 Care and maintenance



NOTE:

Have your vehicle checked once a year by an authorised Invacare® dealer in order to maintain it's driving safety and roadworthiness.

Cleaning the vehicle

When cleaning the vehicle, pay attention to the following points:

- Only use a damp cloth and gentle detergent.
- Do not use any abrasive or scouring liquids.
- Do not subject the electronic components to any direct contact with water.
- Do not use high-pressure cleaning devices.

Disinfection

Spray or wipe disinfection using a tested and recognised product is permitted. A list of the current permitted disinfectants is available from the Robert Koch Institute at <http://www.rki.de/GESUND/DESINF/DESINFLI.HTM>.

Maintenance Jobs	When Delivered	Weekly	Monthly
Seat and backrest padding:			
- Check for perfect condition.			✓
Side part and armrest:			
- Are all fastening elements installed?	✓	✓	
- Can armrests / side parts be removed and installed without too much physical effort?		✓	
- Are armrests secured in their positions?		✓	
Legrests:			
- Do legrests lock into place without any problem? (Only applies to detachable legrests)			✓
- Do the different adjustment functions work without any problem?			✓
Tyres:			
- Have tyres checked for specified air pressure (2,5 bar).	✓	✓	
Front wheel forks / Front wheels			
- Front wheels must be running smoothly.		✓	
- Check fork bearing for firm seat.			✓
Rear wheels:			
- Test wheel for firm seat on the axle drive shaft.			✓
- Rear wheels must turn without wobbling			✓

Maintenance Jobs	When Delivered	Weekly	Monthly
Electronics / Electrical System:			
- Check all plug connections for condition and firm seat.			✓
- Have all batteries been fully charged before the daily operation?	Before every trip		
- Are all holders, screws firmly fixed, tight and safe?			✓
- Are all electric bulbs of the lighting system (if applicable) in working order?	Before each trip		
Cleaning:			
- Clean all parts carefully.	When necessary		

Once a year you should have your wheelchair inspected and serviced by your authorised dealer. If the wheelchair is serviced at regular intervals, damaged or worn parts can be located and replaced in time, thus preserving it in good working order. A complete checklist of necessary maintenance work can be found in the Service Manual, which can be obtained from Invacare®.

11 Repair Instructions

The following are instructions on repairs that can be performed by the user. For the specifications of spare parts please see "**Technical Specifications**" on page **92**, or consult the Service Manual, available from Invacare®. In case you require assistance, please contact your Invacare® Dealer.

11.1 Repairing a flat tyre



WARNING: Danger of damage or injury if the vehicle is accidentally set into motion during repairs!

- *Switch the power off (ON/OFF Button)!*
 - *Engage the motors!*
 - *Secure the vehicle against rolling away by placing wedges under the wheels!*
-

11.1.1 Repairing punctures (drive wheel with conventional motor and pneumatic tyres)



Injury hazard! If the wheel has been insufficiently tightened during assembly, it can become loosened during driving!

- *When reassembling the drive wheels, tighten the Allen screws at a torque of 30 Nm!*
 - *Secure all screws using a suitable blocker (e.g. Loctite 243)!*
-



Requirements:

- Open-ended spanner 5 mm.
 - Torque wrench
 - Repair kit for tyre repair **or** a new inner tube.
 - Talcum powder
 - Screw blocker Loctite (e.g. Loctite 243)
-

Removing the wheel

- Block up the vehicle (place wooden blocks under frame).
- Unscrew 4 screws (1).
- Remove the wheel from the hub.



NOTE:

Re-assembly is done in reverse order. Ensure that the tyre is replaced on the same side and in the same travel direction as it was previously mounted.

Repairing the flat tyre

- Unscrew valve cap.
- Depressurise tyre by pressing in the pin in the valve .
- Remove the 5 cylinder head screws (back of the wheel, 2.
- Remove the rim halves from the tyre.
- Remove the inner tube from the tyre.
- Repair inner tube and replace, or insert new.



NOTE:

If the old inner tube is to be repaired and re-used, and has become wet during repair, you can make replacement easier by sprinkling the inner tube with a little talcum powder.

- Insert the wheel rim halves from outside into the tyre.
- Pump a little air into the inner tube.
- Insert the cylinder head screws in the rim and tighten the wheel rims firmly.
- Ensure that the tyre outer is seated correctly.
- Pump the tyre up to the prescribed pressure.
- Check that the tyre is seated correctly once again.
- Screw the valve cap back on.
- Refit the wheel.

11.1.2 Repairing punctures (drive wheel with GB motor and pneumatic tyres)



EXPLOSION HAZARD!

The wheel will explode if you do not let the air out of the tyre before removing the wheel!

- *Always let the air out of the tyre before removing it (press in the pin in the middle of the valve)!*
-



Injury hazard! If the wheel has been insufficiently tightened during assembly, it can become loosened during driving!

- *When reassembling the drive wheels, tighten the Allen screws at a torque of 30 Nm!*
-



Requirements:

- Open-ended spanner 6 mm.
 - Torque wrench
 - Repair kit for tyre repair **or** a new inner tube.
 - Talcum powder
 - Screw blocker Loctite (e.g. Loctite 243)
-

Disassembly

- Block up the vehicle (place wooden blocks under frame).
- Unscrew valve cap.
- Depressurise tyre by pressing in the pin in the valve (1).
- Unscrew 5 screws (2).
- Remove the wheel rim halves.
- Remove the inner tube from the tyre.

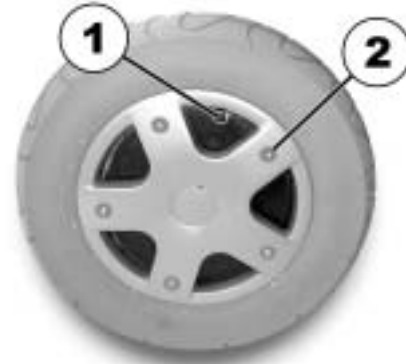

NOTE:

If the old inner tube is to be repaired and re-used, and has become wet during repair, you can make replacement easier by sprinkling the inner tube with a little talcum powder.



NOTE:

Ensure that the tyre is replaced on the same side and in the same travel direction as it was previously mounted.

- Repair inner tube and replace, or insert new.
- Replace the inner tube in the tyre.
- Insert the wheel rim halves once again.
- Insert the screws and tighten slightly.
- Pump a little air into the inner tube.
- Screw the wheel rims tightly together.
- Ensure that the tyre outer is seated correctly.
- Pump the wheel up to its prescribed air pressure (see "**Technical Specifications**" on page **92**)
- Check that the tyre is seated correctly once again.
- Screw the valve cap back on.

12 Refurbishment

The product is suitable for refurbishment. Actions to be carried out:

- Cleaning and disinfection. Please see chapter "**Care and maintenance**" on page **80**.
- Inspection according to service plan. Please consult service instructions, available from Invacare®.
- Adaptation to the user. Please see chapter "**Adjusting the wheelchair to the user's seating posture**" on page **48**.

13 Disposal

- The equipment wrapping is potentially recyclable.
- The metal parts are used for scrap metal recycling.
- The plastic parts are used for plastic recycling.
- Electric components and printed circuit boards are disposed of as electronic scrap.
- Disposal must be carried out in accordance with the respective national legal provisions.
- Ask your city or district council for details of the local waste management companies.

14 Technical Specifications

Electrical system	6 km/h version	10 km/h version	GB version
Motors	• 2 x 400 W	• 2 x 400 W	• 2 x 500 W
Batteries	• 2 x 12V / 60 Ah	• 2 x 12V / 60 Ah	• 2 x 12V / 60 Ah
Main fuse	• 50A	• 50A	• 80 A

Charging device	
Output current	8A ± 8%
Output voltage	24V nominal (12 cells)
Input voltage	200 – 250V nominal
Operating temperature (surroundings)	-25° ... +50°C
Storage temperature	-40° ... +65°C

Tyres	
Tyre pressure	• 2.8 bar

Driving characteristics	6 km/h version	10 km/h version	GB version
Speed	• 6 km/h	• 10 km/h	• 12 km/h
Max. hill-climbing ability without overturning	• 20%	• 20%	• 20%
Max. climbable obstacle height	• 10 cm	• 10 cm	• 10 cm
Turning radius	• 60 cm	• 60 cm	• 60 cm
Drive range in accordance with ISO 7176 ***	• 30 km	• 30 km	• 52 km

Dimensions	Standard	Contour	Recaro	Flex
Total height	• 94	• 105	• 124	• 98
Width of chassis	• 63 cm	• 63 cm	• 63 cm	• 63 cm
Overall width of the seat (with standard armrests)	-	-	• 72 cm	-
Seat width 39 cm	• 60 cm	• 60 cm	-	• 60 cm
Seat width 43 cm	• 64 cm	• 64 cm	-	• 64 cm
Seat width 48 cm	• 69 cm	• 69 cm	-	• 69 cm
Overall width of the seat (with parallel sliding armrests)	-	-	-	-
Seat width 39 cm	• 64 cm	• 64 cm	-	• 64 cm
Seat width 43 cm	• 68 cm	• 68 cm	-	• 68 cm
Seat width 48 cm	• 73 cm	• 73 cm	-	• 73 cm
Overall length (incl. standard legrest)	• 116 cm	• 116 cm	• 116 cm	• 116 cm
Seat height ****	<ul style="list-style-type: none"> • 40 cm (+30 cm with lifter) • 47 cm (+30 cm with lifter) • 45 cm • 47 cm 	<ul style="list-style-type: none"> • 40 cm (+30 cm with lifter) • 47 cm (+30 cm with lifter) • 45 cm • 47 cm 	<ul style="list-style-type: none"> • 40 cm (+30 cm with lifter) • 47 cm (+30 cm with lifter) • 45 cm • 47 cm 	<ul style="list-style-type: none"> • 40 cm (+30 cm with lifter) • 47 cm (+30 cm with lifter) • 45 cm • 47 cm
Seat width (Adjustable armrest area in brackets)	• 43 cm (44 - 48 cm**)	<ul style="list-style-type: none"> • 48 cm (49 - 53 cm**) • 43 cm (44 - 48 cm**) 	• 36 cm (49 - 53 cm**)	<ul style="list-style-type: none"> • 38 cm (39) • 43 (44 - 48 cm**) • 48 (49 - 53 cm**)

Dimensions	Standard	Contour	Recaro	Flex
Seat depth	• 41 / 46 / 51cm	• 41 / 46 / 51cm	• 46 -51 cm	• 41 / 46 / 51cm
Backrest height ****	• 48 / 54 cm	• 64 cm	• 77 - 83 cm	• 55 cm
Seat cushion thickness	• 5 cm	• 7 cm	-	• 7 cm
Backrest angle	• -10°, 0°, +7,5°, +15°, +22,5°, +30°	• -10°...+45° (electr.)	• 0°...+45°	• -10°...+45°
Armrest height	• 25-35 / 29-39 cm	• 25-35 / 29-39 cm	• 25-35 / 29-39 cm	• 25-35 / 29-39 cm
Leg support lengths				
• Short (for leg length 32-38 cm)	• 29.5 - 35.5 cm	• 29.5 - 35.5 cm	• 29.5 - 35.5 cm	• 29.5 - 35.5 cm
• Medium (for leg length 38-44 cm)	• 35.5 - 41.5 cm	• 35.5 - 41.5 cm	• 35.5 - 41.5 cm	• 35.5 - 41.5 cm
• Long (for leg length 44-50 cm)	• 41.5 - 47.5 cm	• 41.5 - 47.5 cm	• 41.5 - 47.5 cm	• 41.5 - 47.5 cm
Seat angle, electronic adjustment (wheelchair without lifter)	• 0° ... +15°	• 0° ... +15°	• 0° ... +15°	• 0° ... +15°
Seat angle, manual adjustment (wheelchair without lifter)	• 0° ... +15°	• 0° ... +15°	• 0° ... +15°	• 0° ... +15°
Seat angle, electronic adjustment (wheelchair with lifter)	• 0° ... +35° • -10 ... +35°	• 0° ... +35° • -10 ... +35°	• 0° ... +35° • -10 ... +35°	• 0° ... +35° • -10 ... +35°

Weight	Without lifter	With lifter
Weight empty (with standard seat and conventional motors)	• 140 kg	• 160 kg
Weight empty (with standard seat and GB motors)	• 160 kg	• 180

Loading

Max. load

- 150 kg

* Approximate.

** Width adjustable for side panel adjustment.

*** Note: The drive range of an electric wheelchair is strongly influenced by external factors, such as the charging state of the batteries, surrounding temperature, local topography, road surface characteristics, tyre pressure, weight of driver, drive style and use of batteries for lighting, servos etc.

**** Measured without seat cushion

15 Inspections Performed

It is confirmed by stamp and signature that all jobs listed in the inspection schedule of the Service and Repair Instructions have been properly performed. The list of the inspection jobs to be performed can be found in the Service Manual which is available through Invacare®.

<u>Delivery Inspection</u>	<u>1st Annual Inspection</u>
Stamp of authorised Dealer / Date / Signature	Stamp of authorised Dealer / Date / Signature
<u>2nd Annual Inspection</u>	<u>3rd Annual Inspection</u>
Stamp of authorised Dealer / Date / Signature	Stamp of authorised Dealer / Date / Signature
<u>4th Annual Inspection</u>	<u>5th Annual Inspection</u>
Stamp of authorised Dealer / Date / Signature	Stamp of authorised Dealer / Date / Signature

Order No. of this Manual: 1435058.DOC

Release Date: 01.03.04

English